

DEVILBISS

SB-E-2-362 ISS.05

CE Ex II 2 G X

Operation Manual

GTi – Pressure Feed Spraygun



E

P 1 - 8



DEVILBISS



Operation Manual

GTi – Pressure Feed Spraygun Important



Read and follow all instructions and Safety Precautions before using this equipment

Description

The GTi Pressure Feed Spraygun Kit is approved to ATEX regulations **94/9/EC**, protection level;
II 2 G X, Suitable for use in Zones 1 and 2

Important: *These Sprayguns are suitable for use with both waterbased and solvent based coating materials. The design uses EPA compliant atomising (Devilbiss Trans-Tech®) technology to reduce overspray and improve coating efficiency. Nozzles and Needles are manufactured in Stainless Steel. These guns are not designed for use with highly corrosive and/or abrasive materials and if used with such materials it must be expected that the need for cleaning and/or replacement of parts will be increased. If there is any doubt regarding the suitability of a specific material contact your local Distributor or ITW Finishing direct.*

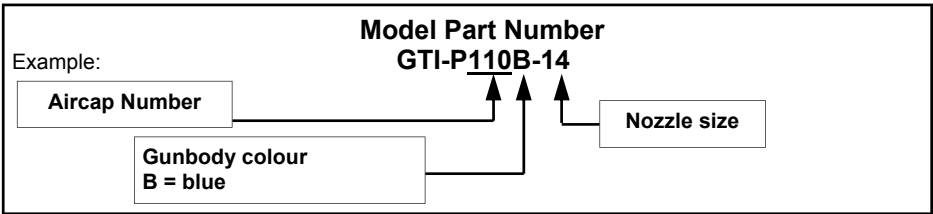

EC Declaration of Conformity

We: **ITW Finishing UK, Ringwood Rd, Bournemouth, Dorset, BH11 9LH, UK**, as the manufacturer of the **Spraygun model GTi-P**, declare, under our sole responsibility, that the equipment to which this document relates is in conformity with the following standards or other normative documents:

BS EN 292-1 PARTS 1 & 2: 1991, BS EN 1953: 1999; and thereby conform to the protection requirements of Council Directive **98/37/EEC** relating to **Machinery Safety Directive**, and;

EN 13463-1:2001, council Directive **94/9/EC** relating to **Equipment and Protective Systems intended for use in Potentially Explosive Atmospheres protection level II 2 G X**.

This product also complies with the requirements of the EPA guidelines, PG6/34.

Transfer efficiency certificates are available on request.

B. Holt, General Manager
30th June 2003



SAFETY WARNINGS

E



Fire and explosion

Solvents and coating materials can be highly flammable or combustible when sprayed. **ALWAYS refer to the coating material suppliers instructions and COSHH sheets before using this equipment**



Users must comply with all local and national codes of practice and insurance company requirements governing ventilation, fire precautions, operation and house-keeping of working areas



This equipment, as supplied, is NOT suitable for use with Halogenated Hydrocarbons.



Static Electricity can be generated by fluid and/or air passing through hoses, by the spraying process and by cleaning non-conductive parts with cloths. To prevent ignition sources from static discharges, earth continuity must be maintained to the spraygun and other metallic equipment used. It is essential to use conductive air and/or fluid hoses.



Personal Protective Equipment



Toxic vapours – When sprayed, certain materials may be poisonous, create irritation or be otherwise harmful to health.

*Always read all labels and safety data sheets for the material before spraying and follow any recommendations. **If In Doubt, Contact Your Material Supplier***



The use of respiratory protective equipment is recommended at all times. The type of equipment must be compatible with the material being sprayed.

Always wear eye protection when spraying or cleaning the spraygun



Gloves must be worn when spraying or cleaning the equipment



Training – Personnel should be given adequate training in the safe use of spraying equipment.

Misuse

Never aim a spraygun at any part of the body

Never exceed the max. recommended safe working pressure for the equipment

The fitting of non-recommended or non-original spares may create hazards

Before cleaning or maintenance, all pressure must be isolated and relieved from the equipment

The product should be cleaned using a gun washing machine. However, this equipment should not be left inside gun washing machines for prolonged periods of time.

Noise Levels

The A-weighted sound level of sprayguns may exceed 85 dB



(A) depending on the set-up being used. Details of actual noise levels are available on request. It is recommended that ear protection is worn at all times when spraying.

Operating

Spray Equipment using high pressures may be subject to recoil forces. Under certain circumstances, such forces could result in repetitive strain injury to the operator.

E

Parts List

Ref. No	Description	Part Number	Qty
1	Air Cap/Retaining ring	GTI-407-	1
1a	Spring Clip	JGA-156-K5	1
+2	Nozzle	SEE CHART	1
3	Baffle & Seal	GTI-425-K	1
	Baffle Seal - Kit of 5	GTI-33-K5	1
+4	Spring Adjusted Needle Packing	Gti-445-K2	1
5	Spreader Valve	GTI-405-K	1
6	Stud and Screw	GTI-408-K5	1
+7	Needle	SEE CHART	1
+8	Spring and Pad	GTI-409-K5	1
9	Bushing	GTI-402-K	1
9a	Seal kit of 5	JGS-72-K5	2
10	Needle Adjusting Screw	GTI-414-K	1
11	Valve Assembly	JGK-449	1
12	Trigger	GTI-108	1
13	Connector	JGA-158	1
14	Airflow Valve	GTI-415-K	1
15	Lock Nut	JGA-51-K5	1
16	Seal	23165-001	1
17	Fluid Inlet Connector and seal	JGA-159-K	1
18	Circlip	25746-007-K5	1
19	Circlip		2
20	Seal & Pin Kit (+ SST-8434-K5)	GTI-428-K5	2
21	Air valve stem assembly	-	1
22	Spring	JGV-262-K5	1

* - * Denotes Aircap Number - Available Aircaps No's 110, 122 and 123
+ - Parts included in service Kit (see accessories)

Chart 1

Nozzle	Needle	Nozzle	Needle
GTI-213-085-K	GTI-449-10-K	GTI-213-15-K	GTI-449-14-K
GTI-213-10-K	GTI-449-10-K	GTI-214-16-K	GTI-420-K
GTI-213-11-K	GTI-449-12-K	GTI-214-18-K	GTI-420-K
GTI-213-12-K	GTI-449-12-K	GTI-214-20-K	GTI-420-K
GTI-213-13-K	GTI-449-14-K	GTI-214-22-K	GTI-420-K
GTI-213-14-K	GTI-449-14-K		

E

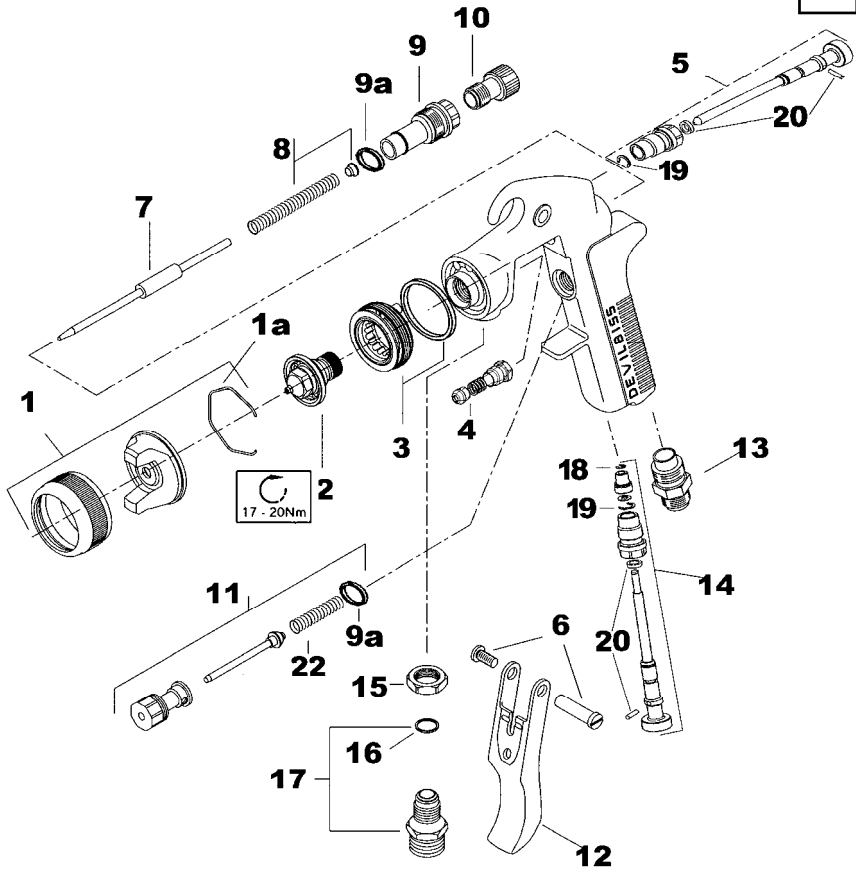

Specification

Air supply connection -	Universal $1/4$ BSP and NPS
Fluid Supply Connection -	Universal $3/8$ BSP and NPS
Maximum static Air inlet pressure -	$P_1 = 9$ bar (130 psi)
Maximum static Fluid inlet pressure -	$P_2 = 14$ bar (200 psi)
Nominal gun Air inlet pressure with gun triggered	2 bar (29 psi)
Maximum Service temperature -	40°C
Gun Weight -	640 g

Materials of Construction

Gun body	-	Anodised Aluminium
Nozzle	-	Stainless steel
Needle	-	Stainless Steel

E

Installation

Important: To ensure that this equipment reaches you in first class condition, protective coatings have been use. **Flush the equipment through with a suitable solvent before use.**

1. Attach air hose to connector (13). Recommended hose size 8 mm
2. Air supply should be filtered and regulated.

bore. The hose must be conductive and electrical bond from the spraygun to earth should be checked with an ohmmeter. A resistance of less than $10^{\circ}\Omega$ is recommended.

Operation

1. Mix coating material to manufacturers instructions
2. Turn needle adjusting screw (10) clockwise to prevent movement.
3. Turn pattern valve (5) counter-clockwise to fully open
4. Adjust inlet air pressure to give 2 bar (29psi) at the gun inlet with the gun triggered. (*pressure gauge attachment shown under Accessories is recommended for this*).
5. Turn needle adjusting screw counter clockwise until first thread shows.
6. Test spray. If the finish is too dry reduce airflow by reducing inlet pressure. If finish is too wet reduce fluid flow by turning needle screw (10) clockwise or reducing the fluid pressure. If atomisation is too coarse, increase inlet air pressure. If too fine reduce inlet pressure.
7. The pattern size can be reduced by turning adjusting valve (5) clockwise.
8. Hold gun perpendicular to surface being sprayed. Arcing or tilting may result in uneven coating.
9. The recommended spray distance is 150-200 mm (6"-8").
10. Spray edges first. Overlap each stroke a minimum of 50%. Move gun at a constant speed.
11. Always turn off air and fluid supply and relieve pressure when gun is not in use.

Air Flow Valve (14)

1. If the airflow valve (14) is fitted this can be used to reduce the inlet pressure through the gun. Screw the Adjusting Knob in to reduce pressure.

Preventative Maintenance

1. Turn off air and coating supply and relieve pressure in the supply lines, or if using QD system, disconnect from airline and fluid line.
2. Remove air cap (1) and clean. If any of the holes in the cap are blocked with coating material use a toothpick to clean. Never use metal wire which could damage the cap and produce distorted spray patterns
3. Ensure the tip of the nozzle (2) is clean and free from damage. Build up of dried paint can distort the spray pattern.

4. Lubrication – stud/screw (6), needle (7) and air valve (11) should be oiled each day.

Replacement of Parts

Nozzle (2) and Needle (7) –

Remove parts in the following order: 10, 8, 7, 1 and 2. Replace any worn or damaged parts and re-assemble in reverse order. Recommended tightening torque for nozzle (2) 17-20 Nm (150-180 lbf in)

Packing – Remove parts 10, 8, 7. Unscrew cartridge (4). Fit new cartridge finger tight. Re-assemble parts 7, 8, and 10 and tighten cartridge (4) with spanner sufficient to seal but to allow free movement of needle. Lubricate with gun oil.

Air valve (11) – Remove Trigger, parts 6 and 12. Unscrew valve assembly. Re-assemble, fitting spring to valve head before fitting valve.

Spreader valve (5) – Caution: always ensure that the valve is in the fully open position by turning screw fully counter-clockwise before fitting to body.

Air cap / Nozzle Selection
Refer to coating material manufacturers recommendations or

Accessories

Spanner – order SPN-5

Cleaning Brush – order 4900-5-1-K3

Service Kit – For sizes 16 to 22 order GTI-416 and nozzle size as required (i.e GTI-416-18)

For sizes 085 to 15 order GTI-426 and nozzle as required size as required (i.e GTI-426-14)

Pressure gauge Attachment – order GA-515

Gun Mounted Regulator – order DVR-501

Lubricant - order GL-1-K10

ITW Finishing Systems and Products
Ringwood Road,
Bournemouth,
BH11 9LH,
England.
Tel. No. (01202) 571111
Telefax No. (01202) 581940,
Website address <http://www.itweuropeanfinishing.com>

ITW Automotive Finishing UK
Anchorbrook Industrial Estate
Lockside
Aldridge,
Walsall,
UK.
Tel. No. (01922) 423700
Telefax No. (01922) 423705,
Website address <http://www.itweuropeanfinishing.com>

ITW Finishing Systems and Products is a Division of ITW
Ltd. Reg. Office:
Admiral House,
St Leonard's Road,
Windsor,
Berkshire,
SL4 3BL,
UK
Registered in England: No 559693 Vat No 619 5461 24

ITW Oberflächentechnik GmbH & Co. KG
Justus-von-Liebig-Straße 31
63128 Dietzenbach
Tel (060 74) 403-1
Telefax: (060 74) 403300
Website address <http://www.itw-finishing.de>

ITW Surfaces Et Finitions
163-171 avenue des Auréats B.P. 1453
26014 VALENCE CEDEX FRANCE
Tél. (33) 475-75-27-00
Télex 345 719F DVILBIS
Téléfax: (33) 475-75-27-99